

22212

12526

3 Hours / 70 Marks

Seat No.

--	--	--	--	--	--	--	--

-
- Instructions* – (1) All Questions are *Compulsory*.
- (2) Answer each next main Question on a new page.
- (3) Illustrate your answer with neat sketches wherever necessary.
- (4) Figures to the right indicate full marks.
- (5) Assume suitable data, if necessary.
- (6) Mobile Phone, Pager and any other Electronic Communication devices are not permissible in Examination Hall.

Marks

- 1. Attempt any FIVE of the following: **10****
- a) Define power and energy.
- b) State the difference between voltage source and current source.
- c) State Kirchoff's current law and Kirchoff's voltage law.
- d) State Ohm's law. Give equation for it.
- e) Give two types of capacitor and give one example of each.
- f) Define breakdown voltage and dielectric strength.
- g) Define Magnetic Flux Density. State its unit.
- h) State Lenz's law.

P.T.O.

- 2. Attempt any THREE of the following: 12**
- a) Define resistance and resistivity. State relationship between them. Give one material having high resistivity.
 - b) Three capacitors $15\ \mu\text{f}$, $18\ \mu\text{f}$ and $12\ \mu\text{f}$ are connected in circuit. Find equivalent capacitance when they are connected in :-
 - i) Series
 - ii) Parallel.
 - c) Draw hysteresis loop for hard steel and silicon steel.
 - d) Differentiate between statically induced emf and dynamically induced emf.
- 3. Attempt any THREE of the following: 12**
- a) State the effects of electric current. Explain any one effect with suitable example.
 - b) Compare resistances in series and parallel.
 - c) Define the terms :-
 - i) Magnetic lines of force
 - ii) Magnetic flux
 - iii) Magnetic flux density
 - iv) Magnetic flux intensity.
 - d) Derive an expression for energy stored in magnetic field.
- 4. Attempt any THREE of the following: 12**
- a) A resistance of $10\ \Omega$ is connected in parallel with $15\ \Omega$. If current through the combination is $10\ \text{ampere}$. Calculate current through each resistance.
 - b) Draw a practical setup to plot charging and discharging curves of a capacitor through a resistor. Draw the curves.
 - c) Explain the magnetization (B – H) curve.

- d) State the Faraday's Law's of electromagnetic induction and state the Fleming's right hand rule.
- e) When a voltage of 220 V is applied to a coil with resistance of 50Ω , produces 5 mWb of flux. If the coil has 1000 turns, find inductance of coil and energy stored in the magnetic field.

5. Attempt any TWO of the following:

12

- a) Explain in detail the symbol and characteristics of ideal voltage source and practical source.
- b) Draw a neat sketch of series magnetic circuit. State value of reluctance for both series and parallel magnetic circuit. Name each term used in them.
- c) Two coils of A of 1000 turns and B of 1200 turns are such that 60% of flux produced by A links with B. A current of 4A in coil A produces a flux of 0.05 Wb and in coil B of 0.075 Wb. Find :-
- L_1
 - L_2
 - M
 - K.

6. Attempt any TWO of the following:

12

- a) Find the current through 5Ω resistor using Kirchoff's Laws in Figure No. 1. Also state the Kirchoff's current law.

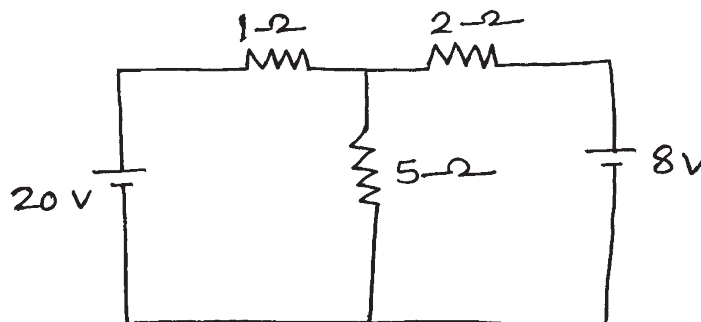

Fig. No. 1

- b) Calculate the value of equivalent capacitance of the combination given in Figure No. 2.

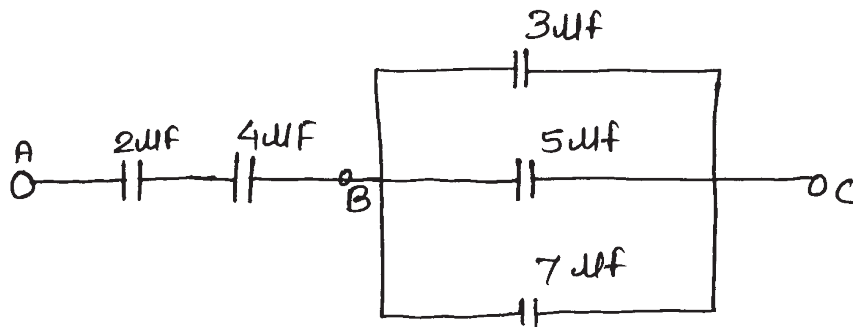

Fig. No. 2

- c) Define self Inductance and prove that

$$L = \frac{N^2}{S}, \text{ where } N = \text{number of turns and } S = \text{reluctance.}$$
