

# 22203

**12223**

**3 Hours / 70 Marks**

Seat No.

--	--	--	--	--	--	--	--

- 
- Instructions* – (1) All Questions are *Compulsory*.
- (2) Illustrate your answers with neat sketches wherever necessary.
- (3) Figures to the right indicate full marks.
- (4) Assume suitable data, if necessary.
- (5) Use of Non-programmable Electronic Pocket Calculator is permissible.
- (6) Mobile Phone, Pager and any other Electronic Communication devices are not permissible in Examination Hall.

**Marks**

- 1. Attempt any FIVE of the following:** **10**
- a) Define force system and state its classification.
- b) State the meaning of reversible machine and state condition for reversibility.
- c) State Polygon Law of forces.
- d) State analytical conditions of equilibrium for coplanar non concurrent force system.
- e) State relation between co-efficient of friction ( $\mu$ ) and angle of friction ( $\phi$ ).
- f) Show the position of centroid of a quarter circle of radius 'R' with a neat sketch.

P.T.O.

- g) Calculate reaction and reactive moment for a cantilever beam loaded as shown in Fig. No. 1.

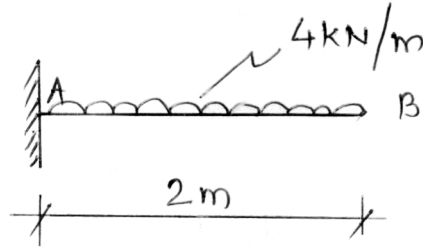

**Fig. No. 1.**

**2. Attempt any THREE of the following: 12**

- Define scalar and vector quantities with two examples of each.
- A screw jack lifts a load of 41.25kN with an effort of 550N, applied at the end of handle of 60 cm. If the pitch of screw is 15 mm, calculate velocity ratio, mechanical advantage and efficiency of the machine.
- For a differential wheel and axle, the diameter of wheel is 36 cm and the diameters of axles are 9 cm and 6 cm. If the efficiency of machine is 80% effort applied is 120N then find the load lifted by it.
- Draw FBD for a ladder of length 'L', self weight 'W', resting on rough horizontal floor and leaning against rough vertical wall. Angle between ladder and horizontal floor =  $\theta$   
Co-efficient of friction at floor =  $\mu_f$   
Co-efficient of friction at wall =  $\mu_w$

3. Attempt any THREE of the following:

12

- a) Find the resultant force in magnitude and direction for the force system shown in Fig. No. 2. Use analytical method.

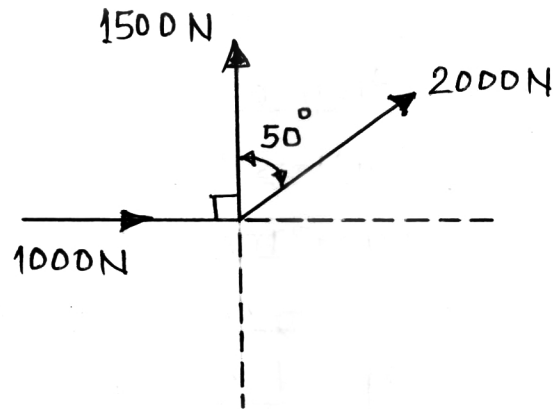

Fig. No. 2.

- b) Find graphically the resultant force in magnitude and direction for the force system shown in Fig. No. 2.
- c) State law of machines and explain it with help of sketch.
- d) A certain machine lift loads of 400N and 600N by an efforts of 60N and 80N respectively. Determine law of machine. Also calculate efficiency at 1kN load if VR is 24.

4. Attempt any THREE of the following:

12

- a) Two forces 40N and 30N are acting at and away from the point and making an angle of  $35^\circ$  with each other. Calculate magnitude and direction of their resultant.
- b) A sphere of weight 750N is placed between two surface as shown in Fig. No. 3. Calculate contact reactions offered by the surfaces.

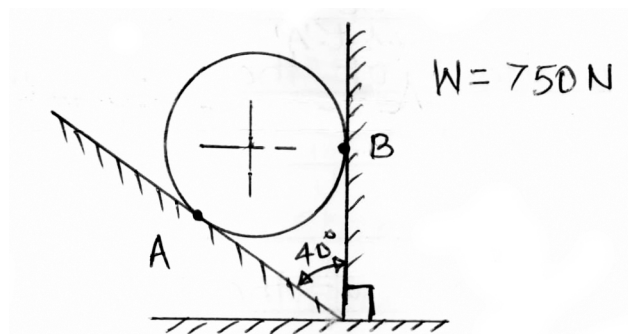
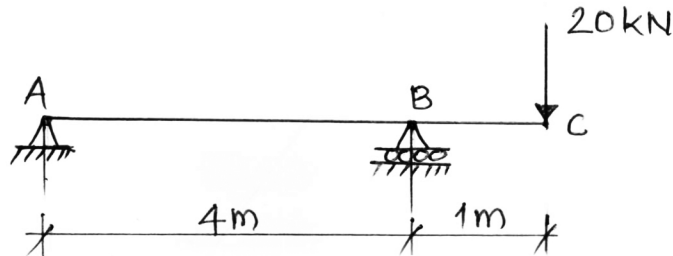

Fig. No. 3.

P.T.O.

- c) Determine the support reactions of a beam loaded as shown in Fig. No. 4.



**Fig. No. 4.**

- d) A body weighing 10 kN is placed in rough horizontal plane for which  $\mu = 0.60$ . Calculate normal reaction, limiting force of friction, horizontal force required just to move it and angle of friction.
- e) Calculate analytically the support reactions of the beam loaded as shown in Fig. No. 5.

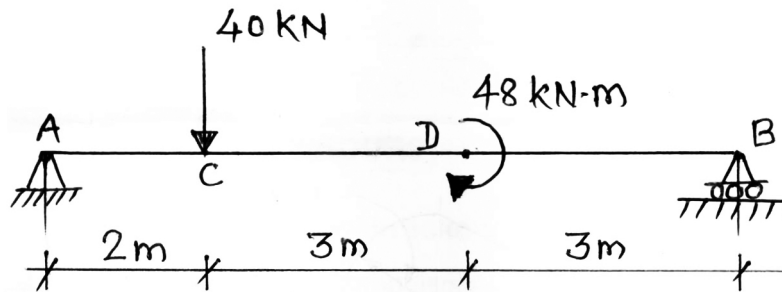
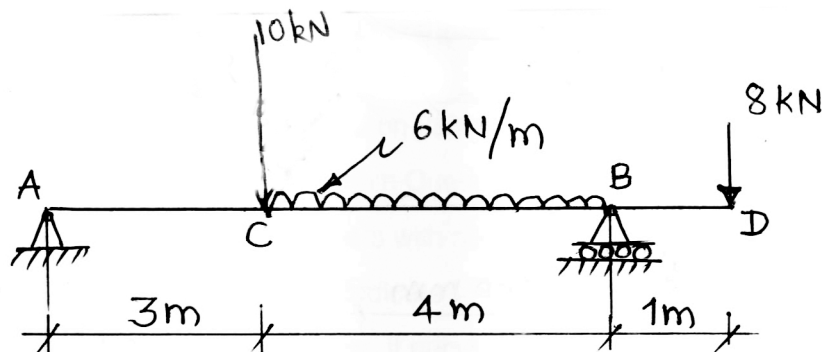

**Fig. No. 5.**

5. Attempt any TWO of the following:

12

- a) Determine analytically the reactions of the beam loaded as shown in Fig. No. 6. Also show the direction of reaction at hinged end.



**Fig. No. 6.**

- b) A block of weight 450N is placed on rough inclined plane making inclination of  $20^\circ$  with horizontal. If  $\mu = 0.24$ , calculate the value of force to be applied parallel to the plane. Just to move the block up the plane.
- c) Calculate magnitude direction and position of the resultant w.r.t. 'A' of the forces shown in Fig. No. 7.

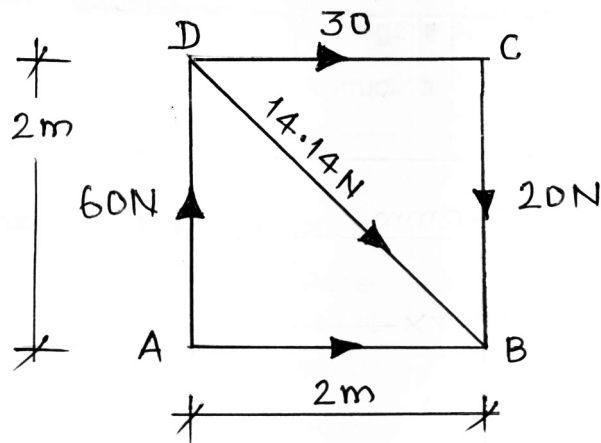

Fig. No. 7.

6. Attempt any TWO of the following:

12

- a) Calculate centroidal position of the lamina of negligible uniform thickness shown in Fig. No. 8.

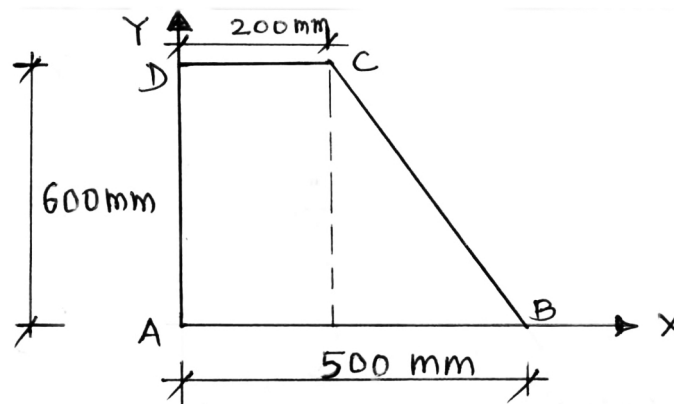
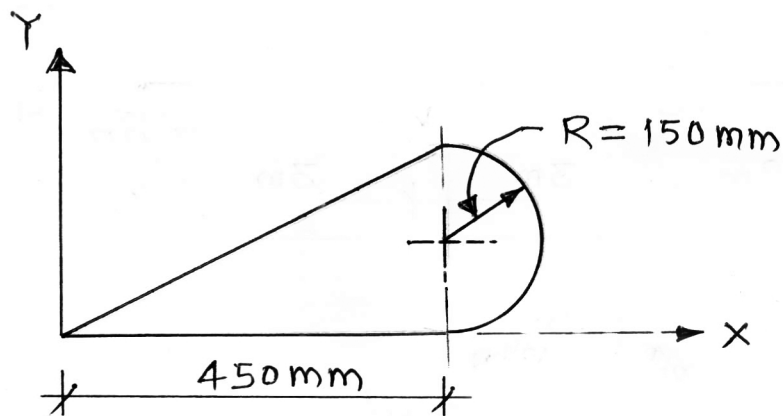

Fig. No. 8.

- b) Locate the centroid of the composite area shown in Fig. No. 9.



**Fig. No. 9.**

- c) Calculate position of center of gravity of the frustrum of cone as shown in Fig. No. 10.

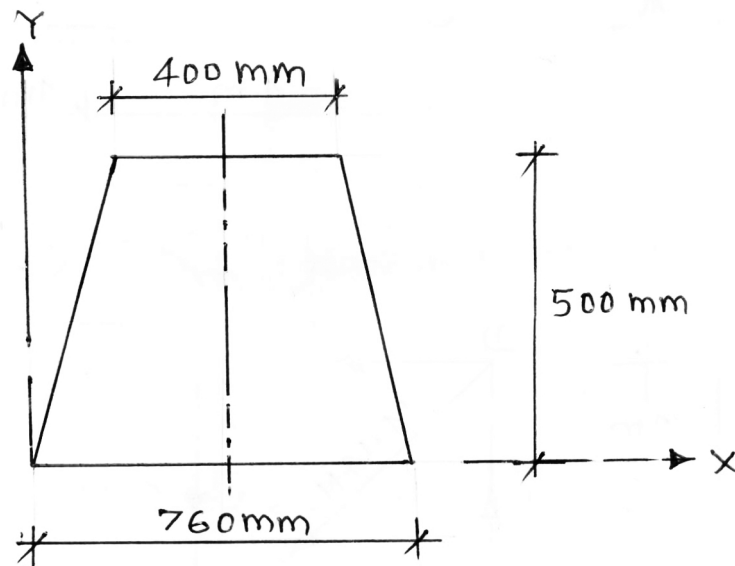

**Fig. No. 10.**